

ACTION PAK® AP4081

MODEL



Benefits

- Adjustable Bridge Excitation 1 to 10V with up to 120mA drive
- Eleven Field Configurable Input Ranges from 10mV to $\pm 200\text{mV}$ (0.5mV/V to $> 50\text{mV/V}$)
- Four (4) Field Configurable Output Ranges: 0-5V, 0-10V, 0-1mA, and 4-20mA
- Easy Plug-in Installation/ Low Mean-Time-to-Repair
- Selectable 120/240VAC
- Lifetime Warranty



Bridge Input, Field Configurable Isolator

Provides an Isolated, DC Output in Proportion to a Bridge/Strain-Gauge Input

DESCRIPTION

The Action Pak AP4081 is a bridge or strain-gauge input signal conditioner with 1500VDC isolation between input, output and power. The field configurable input and output offer flexible, wide ranging capability for bridge or strain-gauge input applications from 0.5mV/V to over 50mV/V.

Wide ranging, precision zero and span pots allow 50% adjustability of offset and gain within each of the 11 switch selectable input ranges. The output can be set for either 0-5V, 0-10V, 0-1mA or 4-20mA.

This flexibility, combined with an adjustable (1 to 10VDC) bridge excitation source, provides the user a reliable, accurate instrument to isolate and condition virtually any bridge or strain-gauge input.

APPLICATION

The Action Pak AP4081 field configurable, bridge input signal conditioner is useful in isolating ground loops and interfacing bridge sensors to data acquisition and control systems.

Three way isolation completely eliminates ground loops from any source. Isolation protects expensive SCADA systems from ground faults and provides filtering for noise reduction, which can be a significant problem with small millivolt bridge signals.

Wide ranging flexibility allows the user to easily zero out dead-loads in weighing systems or configure bipolar input ranges for expansion-compression or vacuum-pressure bridge applications.

The convenient Action Pak is very easy to install using sockets suitable for surface mount, DIN rail mount or snap track mount. Trouble shooting is very easy since no wires need to be removed when swapping units. The wide ranging power supply accepts either 120 or 240VAC power.



Protecting the Integrity of Industrial Process Signals



DIAGNOSTIC LED

The AP4081 is equipped with a dual function LED signal monitor. The green, top mounted LED indicates both line power and input signal status. Active line power is indicated by an illuminated LED. If the input signal is more than 110% of the full-scale range, the LED will quickly flash at 8Hz (or 4Hz when input < 0%). If this continues to occur, you may wish to change your full-scale input range setting or check to make sure the input is connected and not an open circuit.

CONFIGURATION

A major advantage of the AP4081 is its wide ranging capabilities and ease of configuration. The AP4081 has 11 input range switch settings. Trim potentiometers allow 50% input zero and span adjustability within each of the 11 full-scale, input ranges.

For example, the 200mV switch setting in Table 1 configures the input for a 0 to 200mV range. The span can be contracted by 50% which enables an input span of 100mV. This 100mV span can be positioned anywhere within the 0-200mV range. The zero offset can be as large as 50% of the full scale range (e.g. 100 to 200mV range). This can be useful to tare out a dead load in weighing applications.

Unless otherwise specified, the factory presets the Model AP4081 as follows:

Input Setting: 0 to 50mV
 Adjusted Range: 0 to 30mV (3mV/V)
 Excitation: 10V
 Operation: Direct
 Output: 4 to 20mA
 Power: 120VAC

For other I/O ranges refer to Tables 1 through 4 and reconfigure switches SW1 and SW2 for the desired input range, function, excitation and output range.

Warning: Do not attempt to change any switch settings with power applied. Severe damage will result!

CALIBRATION

1. Connect the input to a calibrated millivolt source source, load the excitation supply with the bridge(s) or an equivalent load and apply power. Wait at least 15 minutes for thermal stability before monitoring the voltage/current.
2. Adjust excitation to the desired level.
3. Set the calibrator to the desired minimum input and adjust the zero potentiometer for minimum output.

4. Set the calibrator to the desired maximum input and adjust the span potentiometer for maximum output.
5. Repeat steps 3 and 4, as necessary for best accuracy.

FACTORY ASSISTANCE

For additional information on calibration, operation and installation please contact Action's Technical Services Group. Call toll-free:

800-767-5726

Table 1: Input Range Selector-Switch settings

	SW1				
	1	2	3	4	5
0 to 10mV	■			■	■
0 to 20mV		■	■		■
0 to 50mV			■	■	■
0 to 100mV	■				■
0 to 200mV					■
-5 to 5mV		■			
-10 to 10mV			■		■
-20 to 20mV			■	■	
-50 to 50mV			■	■	■
-100 to 100mV	■				
-200 to 200mV	■				■

KEY ■ = ON

Table 2: Direct or Reverse Operation Setting

	SW1
DIRECT	6
REVERSE	■

Table 3: Bridge Excitation Selector-Switch Settings

	SW1
9.8 to 10.1V	7 8
4.8 to 5.2V	■
0 to 10V	■ ■
0 to 2.5V	■

Table 4: Output Range Selector-Switch Settings

	SW 2					
	1	2	3	4	5	6
0 to 5V	■	■	■	■		
0 to 10V	■		■	■	■	
0 to 1mA		■	■	■	■	
4 to 20mA						■ ■

KEY ■ = ON

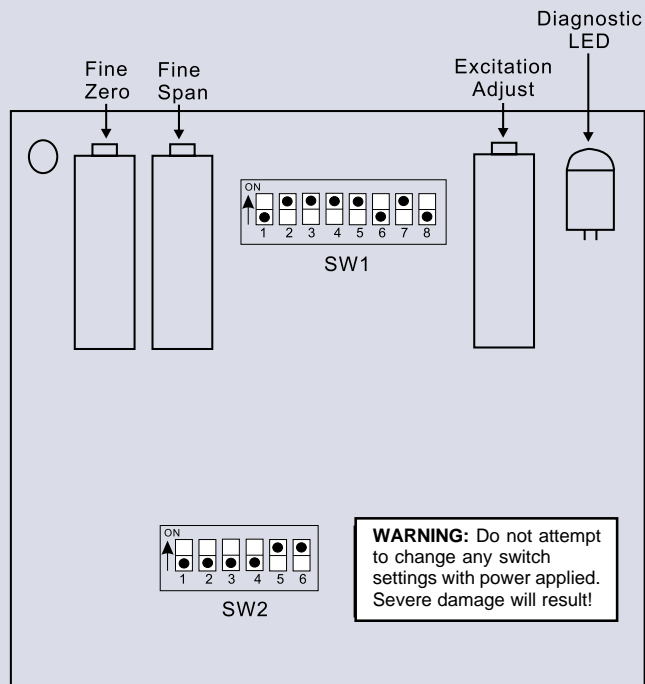

Figure 1: Factory Calibration; 0 to 50mV (calibrated to 0-30mV), 10V excitation, Direct, 4-20mA.

SPECIFICATIONS

Input	Voltage Input	selected range.
	Full Scale Range: 10mV to $\pm 200\text{mV}$ (see Table 1) Impedance: $>1\text{M}\Omega$ Overvoltage: 400Vrms, max (Intermittent); 264 Vrms, max (Continuous) Common Mode (Input to Ground): 1500VDC, max Zero Turn-Up: 50% of full scale range Span Turn-Down: 50% of full scale range Operation: direct or reverse acting	Output Noise (maximum) 0.1% of span, rms, or 10mV whichever is greater. Response Time (10 to 90%) $<200\text{mSec.}$, typical. Common Mode Rejection DC to 60Hz: $>120\text{dB}$, $>100\text{dB}$ on 0-1mA output range Isolation 1500VDC between input, output and power.
Output	Voltage Output	ESD & Transient Susceptibility Meets IEC 801-2, Level 2 (4KV) and IEC 801-4, level 3
	Current Output	LED Indication (green) Input Range $>110\%$ input: 8Hz flash $<-10\%$ input: 4Hz flash
Bridge Excitation	1 to 10VDC, 120mA max (84Ω min)	Humidity (Non-Condensing) Operating: 15 to 95% (@ 45°C) Soak: 90% for 24 hours (@ 65°C)
	Accuracy (Including Linearity, Hysteresis)	Temperature Range Operating: 0 to 60°C (32 to 140°F) Storage: -25 to 70°C (-13 to 158°F)
Stability	$\pm 0.1\%$ typical, $\pm 0.2\%$ maximum of selected range at 25°C .	Power Consumption: 3W typical, 6.5W max. Standard: selectable 120/240VAC, $\pm 10\%$, 50-60Hz
	$\pm 0.025\%/^\circ\text{C}$ typical, $0.05\%/^\circ\text{C}$ maximum, of	Weight AP4081 0.80lbs Agency Approvals CSA certified per standard C22.2 (File No. LR42272-64) UL recognized per standard UL508 (File No. E99775)

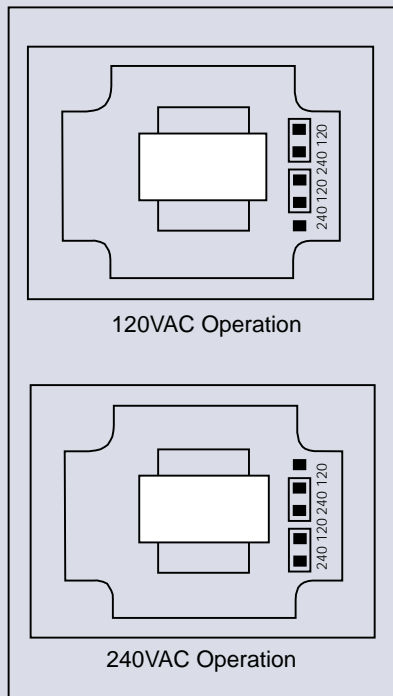

Figure 2: 120/240 VAC Selection

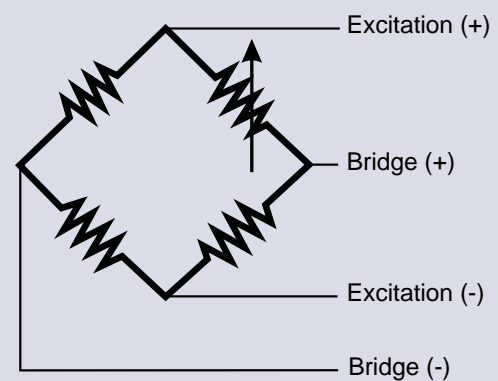
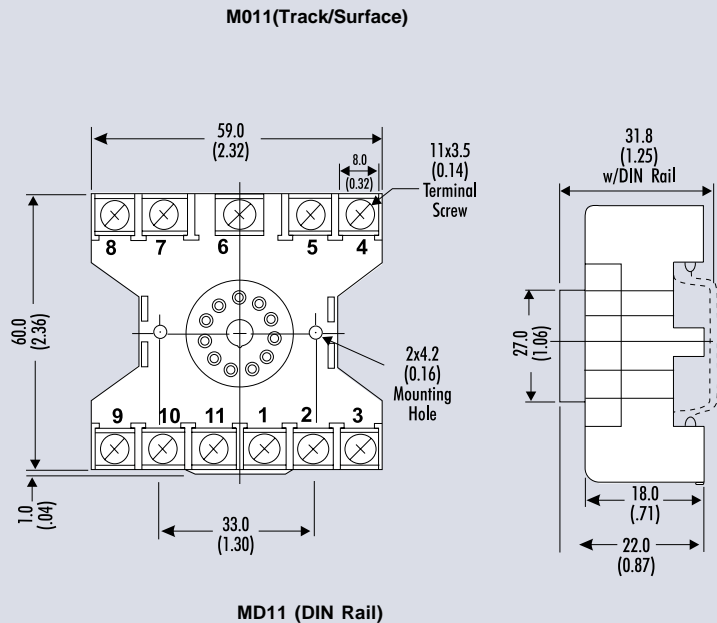
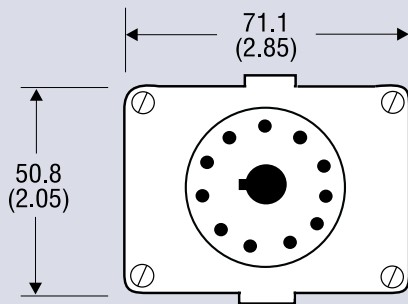
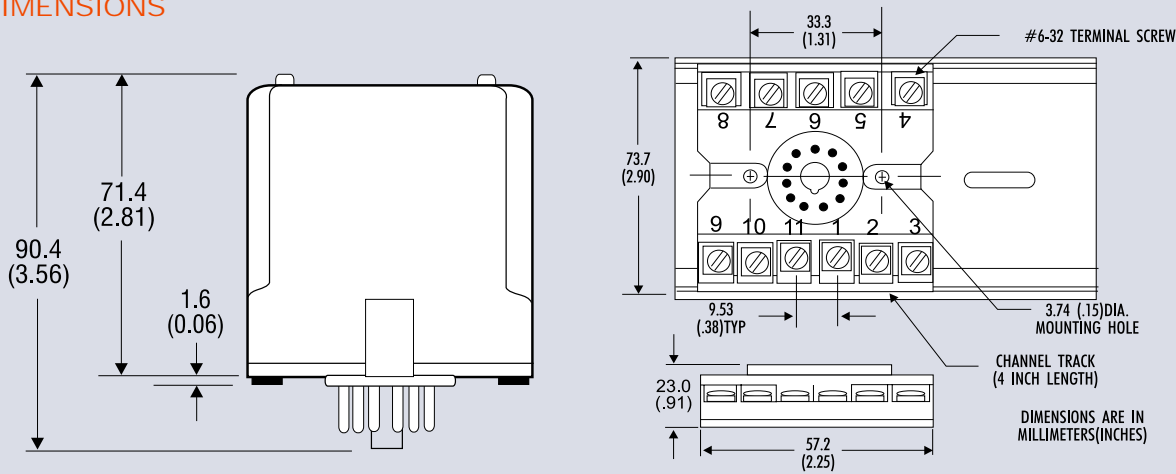

Figure 3: Bridge Reference Designations

DIMENSIONS



MODELS & ACCESSORIES

Mounting

All Action Paks feature plug-in installation. Model AP4081 uses an 11-pin base and either molded socket M011 or DIN socket MD11.

Ordering Information

Specify:

1. Model: **AP4081**
2. Option U, see text
3. Line Power: 120/240VAC
4. Factory Calibration (C620): Specify input range, output range, and power

(All power supplies are transformer-isolated from the internal circuitry.)

Pin Connections*

- 1 AC Power (Hot)
- 2 Do Not Use
- 3 AC Power (Neu)
- 4 Bridge (+)
- 5 Bridge (-)
- 6 Do Not Use
- 7 Excitation (+)
- 8 Excitation (-)
- 9 Output (+)
- 10 Output (-)
- 11 Do Not Use

* Pin 2, 6 and 11 should not be used as terminations for other wires. Connections at these terminals may decrease isolation levels.

大连爱克新仪器有限公司

地址: 辽宁省大连市中山区七七街23号海鹰大厦403室 邮编: 116001

电话: 0411-82650498 82597851 传真: 0411-82650478

网址: 爱克新产品 <http://www.actionio.com.cn>

e-mail: sales@actionio.com.cn support@actionio.com.cn



网址: 欧陆产品 <http://www.eurotherm.com.cn>

e-mail: sales@eurotherm.com.cn support@eurotherm.com.cn