

AP4351

MODEL



Benefits

- Field Configurable Thermocouple Types
- Linearized Outputs
- Wide-Ranging Zero and Span Adjustability (50%)
- Eliminates Ground Loops
- Protects Equipment with 1500V Input-to-Output Isolation
- Thermocouple Burnout Detection
- ASIC Reliability
- Lifetime Warranty



Action Pak® Thermocouple-Input, Field Configurable Isolator

Provides Isolated, Linearized DC Output in Proportion to Thermocouple Input

DESCRIPTION

The AP4351 isolating thermocouple conditioner offers wide ranging input and output capability. The AP4351 can be field configured by the user to accept input from thermocouple types J, K, T, R, S, E, and B and to provide current or voltage output. The output is linearized to temperature according to the particular thermocouple type.

The AP4351 is a three-port industrial isolator — the output is optically isolated from the input up to 1500V, and both input and output are transformer isolated from the line power. Isolation allows the noise reduction benefits of grounded thermocouples to be realized without creating ground loop problems and it provides faster response. The AP4351 utilizes the latest in advanced analog/digital signal processing technology. In addition to its multiple microprocessors, it employs special ASIC circuitry for high accuracy and reliability.

The AP4351 is equipped with cold-junction compensation (CJC) circuitry to provide ice-point reference. Upscale, downscale or disabled thermocouple burnout detection is switch selectable.

APPLICATION

The Action Pak Model AP4351 is useful in any application requiring an isolated DC output from a thermocouple input. Typical applications include energy management and data acquisition of process temperatures. The output of the AP4351 can drive a digital meter for direct display or interface with a computer for monitoring and control applications.

STATUS LEDs

Model AP4351 is equipped with top-mounted LEDs for INPUT (green), TROUBLE (yellow) and CAL OK (yellow). At start-up, both the INPUT and the CAL OK LEDs light up momentarily for 1 second. Afterwards, these LEDs flash alternately for 10 seconds while start-up takes place.



INPUT LED

This input LED is a diagnostic tool. It remains continuously lit if the measured temperature is within the selected range of the thermocouple. However, if the measured temperature is outside the full range of the thermocouple (for example, for a type J - below minus 200°C or above 750°C), the LED will flash at a rate of 4 or 8Hz for under/over range, respectively. If the thermocouple is within the full temperature range, but outside the selected sub-range (for example, if a type J thermocouple is set for range 13 and the temperature is either below 375°C or above 500°C) the LED will flash at 0.5 or 1Hz respectively.

CAL OK LED

This LED is continuously on when the device is properly storing the factory calibration reference voltage.

TROUBLE LED

This LED is off during normal operation of the device. If this LED is on contact Action's Technical Services Group.

OPTIONS

- U Urethane coating of internal circuitry for protection from corrosive atmospheres.
- C620 Factory calibration (specify input thermocouple type, temperature range and output).

CONFIGURATION

A major advantage of the AP4351 is its wide ranging capabilities and ease of configuration. The AP4351 enables 50% input zero and span adjustability within the selected sub-range.

For example, range #5 for an E-Type thermocouple in Table 6 specifies -18°C to 125°C. Since the span can be contracted by 50%, this enables an input span as narrow as 50% of 143°C, or 72°C. This span can then be positioned anywhere within the temperature range and can have a zero step-up as large as 50% of the full scale range (e.g. span can start as high as 53°C).

Unless otherwise specified, the factory pre-sets the Model AP4351 as follows:

Input: J-type
 Range: 0-500°C
 Output: 4-20mA
 Burn Out: Upscale

For other settings, remove the four base screws and polycarbonate case to access the configuration switches.

Refer to Tables 1 through 6 and Figures 1 through 3 for the proper switch locations and settings. Using the switch on the input board select thermocouple type, temperature range,

and thermocouple burnout detection. Using the switch on the output board, select desired type of output. Replace the case prior to applying power to the unit.

CALIBRATION

1. Connect the input to a calibrated thermocouple source and apply power. Wait 1-2 hours for thermal stability before monitoring the voltage/current output. Refer to PIN CONNECTIONS.
2. Set the calibrator to the desired minimum input and adjust the zero potentiometer for the desired minimum output.
3. Set the calibrator to the desired maximum input and adjust the span potentiometer for the desired maximum output.

4. Repeat steps 2 and 3, as necessary, for best accuracy.

INSTALLATION

Model AP4351 is pin-compatible with Action's AP4100, AP4130, AP4150, and AP4350, allowing for easy field upgrade.

FACTORY ASSISTANCE

For additional information on calibration, operation and installation please contact Action's Technical Services Group. Call toll-free:

800-767-5726

Table 1: Thermocouple type switch settings (SW 1 on Input Board)

TC Type	8	9	10
B	ON	ON	ON
E	ON	ON	OFF
J	ON	OFF	ON
K	ON	OFF	OFF
R	OFF	ON	ON
S	OFF	ON	OFF
T	OFF	OFF	ON
Not Used	OFF	OFF	OFF

Table 2: Range switch settings used in conjunction with Table 6 (SW 1 on Input Board, SW1-3 is not used)

Input Sub-Range	SW1-7	SW1-6	SW1-5	SW1-4
1	OFF	ON	OFF	ON
2	OFF	ON	ON	ON
3	ON	OFF	ON	OFF
4	OFF	OFF	ON	ON
5	ON	ON	OFF	ON
6	ON	ON	ON	ON
7	ON	OFF	OFF	ON
8	OFF	OFF	OFF	ON
9	ON	ON	ON	OFF
10	OFF	ON	ON	OFF
11	OFF	ON	OFF	OFF
12	OFF	OFF	ON	OFF
13	ON	ON	OFF	OFF
14	ON	OFF	ON	ON
15	ON	OFF	OFF	OFF
16	OFF	OFF	OFF	OFF

Table 3: Thermocouple burnout detection switch settings (SW 1 on Input Board)

TC Burnout Detect	SW1-2	SW1-1
Upscale	OFF	ON
Downscale	ON	OFF
Disable	OFF	OFF
Not Allowed	ON	ON

Table 4: Output switch settings (SW 1 on Output Board)

Output	SW1-2	SW1-1
0 - 5V	ON	ON
0 - 10V	OFF	ON
0 - 1mA	ON	OFF
4 - 20mA	OFF	OFF

Table 5: AP 4351 Accuracy

TC Type	Temp. Range °C (°F)	Accuracy
J	-200 to 750°C (-328 to 1382°F)	±2.0 °C (±3.6°F)
K	-200 to -140°C (-328 to -220°F)	±5.0 °C (±9.0°F)
	-140 to 1250°C (-220 to 2282°F)	±2.0 °C (±3.6°F)
E	1250 to 1370°C (2282 to 2498°F)	±4.0 °C (±7.2°F)
	-150 to 1000°C (-238 to 1832°F)	±2.5 °C (±4.5°F)
T	-150 to 400°C (-238 to 752°F)	±3.0 °C (±5.4°F)
R	50 to 1760°C (122 to 3200°F)	±6.0 °C (±10.8°F)
S	50 to 1760°C (122 to 3200°F)	±6.0 °C (±10.8°F)
B	500 to 1820°C (932 to 3308°F)	±5.0 °C (±9.0°F)

SPECIFICATIONS

Inputs	Ranges: field configurable, see Table 6 Impedance: >1M Ω Input Bias Current (burnout detection): <1.5 microamp Overvoltage: \pm 10V differential Common Mode (Input to Ground): 1500VDC or peak AC, max Zero and Span Range: Zero Turn-Up: 0 to 50% of full scale range Span Turn-Down: 100 to 50% of full scale range	ESP Susceptibility	Meets IEC 801-2, Level 2 (4KV)
Outputs	Voltage Output: field-configurable Ranges: 0-5V, 0-10V Impedance: <10 Ω Drive: 10mA, max.(1K Ω , min.) Current Output: field-configurable Ranges: 0-1mA, 4-20mA Impedance: >100K Ω Compliance: 10V, max. (500 Ω , max. @ 20mA)	Common Mode Rejection	DC - 60Hz: 120dB
Accuracy (Including Linearity, Hysteresis)	see Table 5	LED Indicators	TROUBLE LED: Yellow - off during normal device operation INPUT LED: Green - continuously on if input is within selected range, flashes otherwise CAL OK LED: Yellow - continuously on in normal device operation
Response Time	(10-90%) 500 mSec, typical	Thermocouple Burnout Detect	Field-configurable Up or Downscale, or disabled
Stability	\pm 0.04%/ $^{\circ}$ C of full scale range	Humidity (Non-Condensing)	Operating: 25 to 95% (@ 45 $^{\circ}$ C) Soak: 90% for 24 Hrs. (@65 $^{\circ}$ C)
Isolation	1500VDC or peak AC between input, output and power	Temperature Range	Operating: 0 to 60 $^{\circ}$ C (32 to 140 $^{\circ}$ F) Storage: -15 to 75 $^{\circ}$ C (5 to 167 $^{\circ}$ F)
		Power	Consumption: 3W typical, 5W max Standard: 120VAC \pm 10%, 50 - 60Hz Optional: 240VAC
		Weight	0.62lbs
		Approvals	UL recognized per standard UL508. (File No. E99775). CSA certified per standards C22.2 No. M1982 (File No. LR42272-41).

Table 6: Thermocouple Range Settings

TC Type	Range#	Temperature Range		TC Type	Range#	Temperature Range		
B	6	500 to 1820 $^{\circ}$ C	(932 to 3308 $^{\circ}$ F)	K (cont.)	4	-18 to 250 $^{\circ}$ C	(0 to 482 $^{\circ}$ F)	
	7	1000 to 1820 $^{\circ}$ C	(1832 to 3308 $^{\circ}$ F)		5	-18 to 125 $^{\circ}$ C	(0 to 257 $^{\circ}$ F)	
	8	500 to 1000 $^{\circ}$ C	(932 to 1832 $^{\circ}$ F)		7	1000 to 1370 $^{\circ}$ C	1832 to 2498 $^{\circ}$ F)	
	11	1500 to 1820 $^{\circ}$ C	(2732 to 3308 $^{\circ}$ F)		8	500 to 1000 $^{\circ}$ C	(932 to 1832 $^{\circ}$ F)	
	12	750 to 1000 $^{\circ}$ C	(1382 to 1832 $^{\circ}$ F)		9	250 to 500 $^{\circ}$ C	(482 to 932 $^{\circ}$ F)	
E	2	-18 to 1000 $^{\circ}$ C	(0 to 1832 $^{\circ}$ F)		10	125 to 250 $^{\circ}$ C	(257 to 482 $^{\circ}$ F)	
	3	-18 to 500 $^{\circ}$ C	(0 to 932 $^{\circ}$ F)		12	750 to 1000 $^{\circ}$ C	(1382 to 1832 $^{\circ}$ F)	
	4	-18 to 250 $^{\circ}$ C	(0 to 482 $^{\circ}$ F)		13	375 to 500 $^{\circ}$ C	(707 to 932 $^{\circ}$ F)	
	5	-18 to 125 $^{\circ}$ C	(0 to 257 $^{\circ}$ F)		14	-200 to 750 $^{\circ}$ C	(-328 to 1382 $^{\circ}$ F)	
	8	500 to 1000 $^{\circ}$ C	(932 to 1832 $^{\circ}$ F)		15	-200 to 250 $^{\circ}$ C	(-328 to 482 $^{\circ}$ F)	
	9	250 to 500 $^{\circ}$ C	(482 to 932 $^{\circ}$ F)		16	-200 to 0 $^{\circ}$ C	(-328 to 32 $^{\circ}$ F)	
	10	125 to 250 $^{\circ}$ C	(257 to 482 $^{\circ}$ F)		R, S	1	50 to 1760 $^{\circ}$ C	(122 to 3200 $^{\circ}$ F)
	12	750 to 1000 $^{\circ}$ C	(1382 to 1832 $^{\circ}$ F)			2	50 to 1000 $^{\circ}$ C	(122 to 1832 $^{\circ}$ F)
	13	375 to 500 $^{\circ}$ C	(707 to 932 $^{\circ}$ F)			3	50 to 500 $^{\circ}$ C	(122 to 932 $^{\circ}$ F)
	14	-150 to 750 $^{\circ}$ C	(-238 to 1382 $^{\circ}$ F)			4	50 to 250 $^{\circ}$ C	(122 to 482 $^{\circ}$ F)
	15	-150 to 250 $^{\circ}$ C	(-238 to 482 $^{\circ}$ F)			7	1000 to 1760 $^{\circ}$ C	(1832 to 3200 $^{\circ}$ F)
16	-150 to 0 $^{\circ}$ C	(-238 to 32 $^{\circ}$ F)	8	500 to 1000 $^{\circ}$ C		(932 to 1832 $^{\circ}$ F)		
			9	250 to 500 $^{\circ}$ C		(482 to 932 $^{\circ}$ F)		
J	2	-18 to 750 $^{\circ}$ C	(0 to 1382 $^{\circ}$ F)	10	125 to 250 $^{\circ}$ C	(257 to 482 $^{\circ}$ F)		
	3	-18 to 500 $^{\circ}$ C	(0 to 932 $^{\circ}$ F)	11	1500 to 1760 $^{\circ}$ C	(2732 to 3200 $^{\circ}$ F)		
	4	-18 to 250 $^{\circ}$ C	(0 to 482 $^{\circ}$ F)	12	750 to 1000 $^{\circ}$ C	(1382 to 1832 $^{\circ}$ F)		
	5	-18 to 125 $^{\circ}$ C	(0 to 257 $^{\circ}$ F)	13	375 to 500 $^{\circ}$ C	(707 to 932 $^{\circ}$ F)		
	8	500 to 750 $^{\circ}$ C	(932 to 1382 $^{\circ}$ F)	T	3	-18 to 400 $^{\circ}$ C	(0 to 752 $^{\circ}$ F)	
	9	250 to 500 $^{\circ}$ C	(482 to 932 $^{\circ}$ F)		4	-18 to 250 $^{\circ}$ C	(0 to 482 $^{\circ}$ F)	
	10	125 to 250 $^{\circ}$ C	(257 to 482 $^{\circ}$ F)		5	-18 to 125 $^{\circ}$ C	(0 to 257 $^{\circ}$ F)	
	13	375 to 500 $^{\circ}$ C	(707 to 932 $^{\circ}$ F)		9	250 to 400 $^{\circ}$ C	(482 to 752 $^{\circ}$ F)	
	14	-200 to 750 $^{\circ}$ C	(-328 to 1382 $^{\circ}$ F)		10	125 to 250 $^{\circ}$ C	(257 to 482 $^{\circ}$ F)	
	15	-200 to 250 $^{\circ}$ C	(-328 to 482 $^{\circ}$ F)		13	375 to 400 $^{\circ}$ C	(707 to 752 $^{\circ}$ F)	
16	-200 to 0 $^{\circ}$ C	(-328 to 32 $^{\circ}$ F)	14		-150 to 400 $^{\circ}$ C	(-238 to 752 $^{\circ}$ F)		
K	1	-18 to 1370 $^{\circ}$ C	(0 to 2498 $^{\circ}$ F)		15	-150 to 250 $^{\circ}$ C	(-238 to 482 $^{\circ}$ F)	
	2	-18 to 1000 $^{\circ}$ C	(0 to 1832 $^{\circ}$ F)		16	-150 to 0 $^{\circ}$ C	(-238 to 32 $^{\circ}$ F)	
	3	-18 to 500 $^{\circ}$ C	(0 to 932 $^{\circ}$ F)					

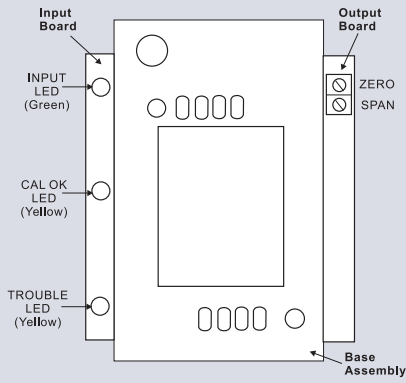

Figure 1: Top View

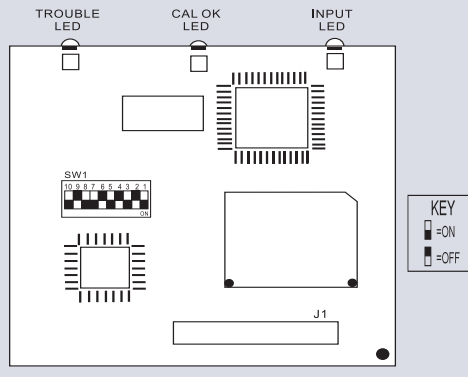

Figure 2: Input Board

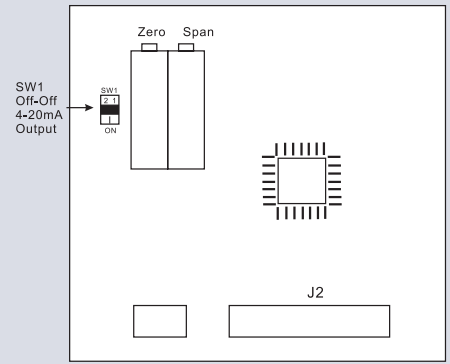
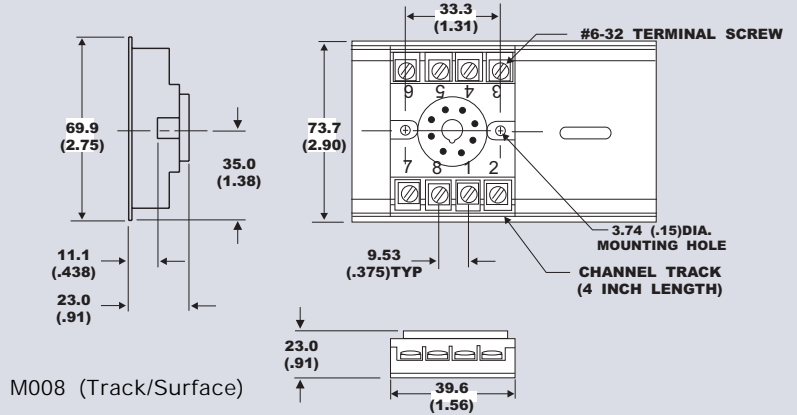
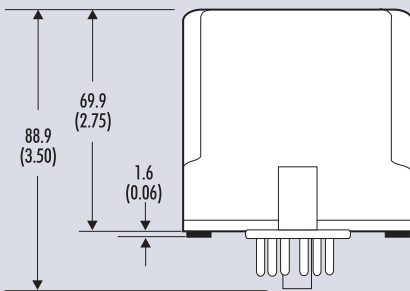

Figure 3: Output Board

DIMENSIONS

Dimensions are in mm (inches)



M008 (Track/Surface)

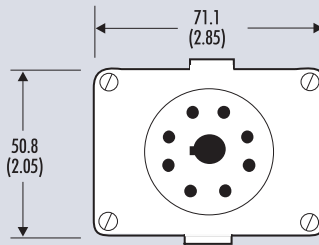

MD08 (DIN/Surface)

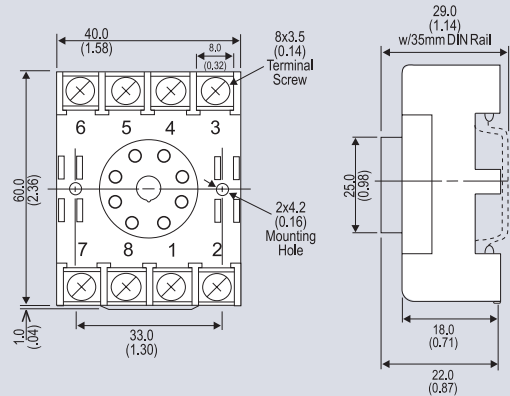

MODELS & ACCESSORIES

Mounting

All Action Paks feature plug-in installation. Model AP4351-2000 uses an 8-pin base and molded-sockets M008, or DIN-socket MD08.

Ordering Information

Specify:

1. Model: AP4351-2000
2. Option: C620 factory calibration (specify input thermocouple type, temperature range and output).
3. Option: U, see text
4. Line Power, see specifications (All power supplies are transformer-isolated from the internal circuitry)

Pin Connections

AP4351-2000

1. Power (Hot)
2. No Connection
3. Power (Neu)
4. Do not use
5. Input (+)
6. Input (-)
7. Output (+)
8. Output (-)

大连爱克新仪器有限公司

地址: 辽宁省大连市中山区七七街23号海鹰大厦403室 邮编: 116001

电话: 0411-82650498 82597851 传真: 0411-82650478

网址: 爱克新产品 <http://www.actionio.com.cn>

e-mail: sales@actionio.com.cn support@actionio.com.cn
An Invensys company

网址: 欧陆产品 <http://www.eurotherm.com.cn>

e-mail: sales@eurotherm.com.cn support@eurotherm.com.cn

