

ACTION PAK® AP4382 MODEL



Benefits

- Eliminates Ground Loops with 1500V Input-to-Output Isolation
- Easy Field Configurable Input Ranges: 10mV to 100V, 1mA to 100mA
- Two (2) Field Configurable Output Ranges: -5 to 5V and -10 to 10V
- Easy Plug-in Installation/ Low Mean-Time-to-Repair
- Selectable 120/240VAC Power (9 TO 30VDC Available)
- CSA Certified, UL Recognized
- ASIC Technology for High Reliability
- Lifetime Warranty



DC Input, Bipolar Output, Field Configurable Isolator

Provides a Fully Isolated DC Output in Proportion to DC Input

DESCRIPTION

The field configurable AP4382 isolator offers wide ranging input and output capability for scaling and transmitting analog DC signals. The AP4382 will accept input voltage spans from 10mV up to 100 volts, as well as input current spans from 1mA to 100mA. The input zero and span potentiometers enable 50% input zero and span adjustability. For example, the 0-10V input range can be elevated to 5-10V, or compressed to 0-5V. The AP4382 offers two (2) bipolar output ranges: -5 to 5V and -10 to 10V.

Model AP4382 also accepts bipolar inputs and offers selectable normal or reverse acting operation

The AP4382 is an industrial isolator —the output is optically isolated from its input up to 1500 VDC. The ASIC*-based I/O channel is independently transformer isolated from the selectable 120/240VAC power supply.

APPLICATION

The Action Pak AP4382 field configurable isolator is useful in eliminating ground loops, converting signal levels and providing signal drive. The wide ranging capability of the AP4382 provides quick universal spare part coverage.

DIAGNOSTIC LED

The AP4382 is equipped with a dual function LED signal monitor. The green, top-mounted LED indicates line power and input signal status. Active line power is indicated by an illuminated LED. If the input signal is 10% above the full scale range, the LED will flash at 8Hz. Below 0%, the flash rate is 4Hz.

OPTION

- U Urethane coating of internal circuitry for protection from corrosive atmospheres.

*ASIC - Application Specific Integrated Circuit.



CONFIGURATION

The factory preset input is 4-20mA and the output is -10 to 10V, as shown in Figure 1. The supply power is configured for 120 VAC operation. For other I/O ranges, remove the four base screws and case to access the I/O card.

Refer to Figure 1 for configuration and program the I/O channel as desired.

Replace the cover before applying power.

WARNING: Do not attempt to change any switch settings with power applied. Severe damage will result!

INPUT

1. Position input jumper "W1" for Current (I) or Voltage (V) input.

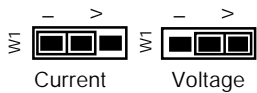

2. Set position 5 of the Input Range Selector for Unipolar (e.g. 0 to 5V) or Bipolar (e.g. -5 to 5V) operation.

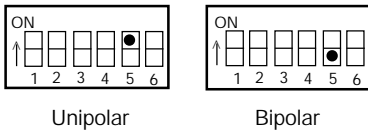

Note: A bipolar range selection will double any input range from Table 1 (e.g. 10V span = -10 to 10V bipolar span)

3. Set position 6 of the Input Range Selector for Normal or Reverse operation. Reverse acting produces a decreasing output with an increasing input.

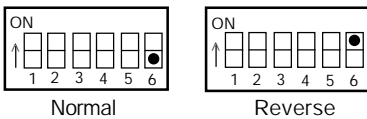

4. Using Table 1, configure positions 1 through 4 of the Input Range Selector for the desired maximum input. Round the desired maximum input value to the next highest range (e.g., 0-70V = 100V range).

WARNING: Do not configure the output ranges with the power on. Damage to unit will result.

OUTPUT

1. Position output jumper "W2" for -5 to 5V or -10 to 10 V

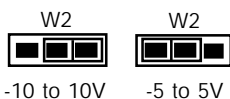

POWER

1. Configure the AC jumpers for either 120 or 240 VAC operation. See Figure 2.

CALIBRATION

1. Connect the input to a calibrated DC voltage or current source and apply power. Wait 1 hour for thermal stability before monitoring the voltage/current output. Refer to PIN CONNECTIONS.

2. Set the calibrator to the desired minimum input and adjust the Zero, 20-turn, potentiometer for desired minimum output.

3. Set the calibrator to the desired maximum input and adjust the Span, 20-turn, potentiometer for desired maximum output.

4. Repeat steps 2 and 3 for best accuracy.

FACTORY ASSISTANCE

For additional information on calibration, operation and installation please contact Action's Technical Services Group. Call toll-free:

800-767-5726

Table 1: AP4382 Input Ranges

Voltage*	Current*	Input Range Selector (SW1)
20mV	2mA	
50mV	5mA	
100mV	10mA	
200mV	20mA	
500mV	50mA	
1V	100mA	
2V		
5V		
10V		
25V		
50V		
100V		

*Note: Use jumper (W1) to configure either voltage or current input. For split range current inputs (e.g. 4-12mA, 12-20mA) or high voltage inputs >100V consult factory.

SPECIFICATIONS

Input	<p>Voltage Input (field configurable) Full Scale Range: 10mV to 100V Impedance: >100KΩ Overvoltage: 400 Vrms, max (Intermittent): 264 Vrms, max (Continuous)</p> <p>Current Input (field configurable) Full Scale Range: 1mA to 100mA Impedance: 20Ω, typical Overcurrent: 170mArms, max Overvoltage: 60VDC Common Mode (Input to Ground): 1500VDC, max</p>	<p>Accuracy (Including Linearity, Hysteresis)</p> <p>Response Time (10-90%)</p> <p>Stability (Temperature)</p> <p>Common Mode Rejection</p> <p>Isolation (Input to Output)</p> <p>ESD Susceptibility</p> <p>Humidity (Non-Condensing)</p>	<p><20mV/2mA: $\pm 0.35\%$ of full scale, typical, 0.5%, max >20mV/2mA: $\pm 0.1\%$ of full scale, typical, 0.2%, max 200 mSec., typical $\pm 0.025\%$ of full scale/$^{\circ}\text{C}$, typical, $\pm 0.05\%$/$^{\circ}\text{C}$, max DC to 60Hz: 120dB 1500 VDC between input, output and power Meets IEC 801-2, Level 2 (4kV) Operating: 15 to 95% (@ 45$^{\circ}\text{C}$) Soak: 90% for 24 hours (@ 65$^{\circ}\text{C}$)</p>
Zero and Span Range	<p>Zero Turn-Up: 0 to 50% of full scale range Span Turn-Down: 100 to 50% of full scale range</p>	<p>Temperature Range</p>	<p>Operating: -15 to 60$^{\circ}\text{C}$ (5 to 140$^{\circ}\text{F}$) Storage: -25 to 70$^{\circ}\text{C}$ (-13 to 158$^{\circ}\text{F}$)</p>
Output	<p>Voltage Output Output: -10 to 10V, -5 to 5V Impedance: <10Ω Drive: 10mA, max (1KΩ min. @ 10V)</p>	<p>Power</p>	<p>Consumption: 3W typical, 5W max Standard: selectable 120/240VAC, $\pm 10\%$, 50-60Hz Optional: 9 to 30VDC, inverter isolated</p>
LED Indication (green)	<p>Input Range >110% input: 8Hz flash <0% input: 4Hz flash</p>	<p>Weight</p> <p>Agency Approvals</p>	<p>0.60lbs CSA certified per standard C22.2, No. M1982 (File No. LR42272-54). UL recognized per standard UL508 (File No. E150323).</p>

I/O CARD CONFIGURATION

WARNING: Applying voltage to the input with W1 in current (I) position will result in damage to the unit.

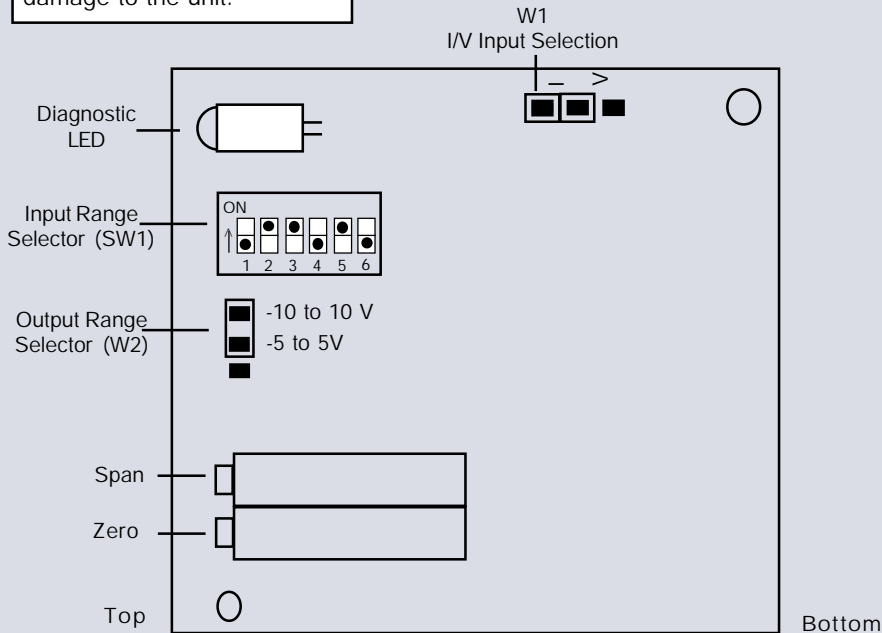

Figure 1: AP4382 I/O card
 factory calibration: 4-20mA input, -10 to 10V output
 (shown sideways to view switches)

WARNING: Do not configure I/O switch ranges with power on.
 Damage will result!

TOP VIEW DIAGRAM

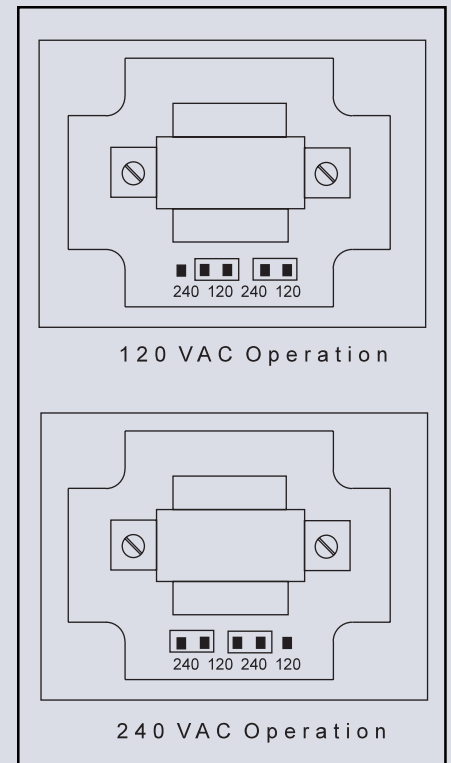
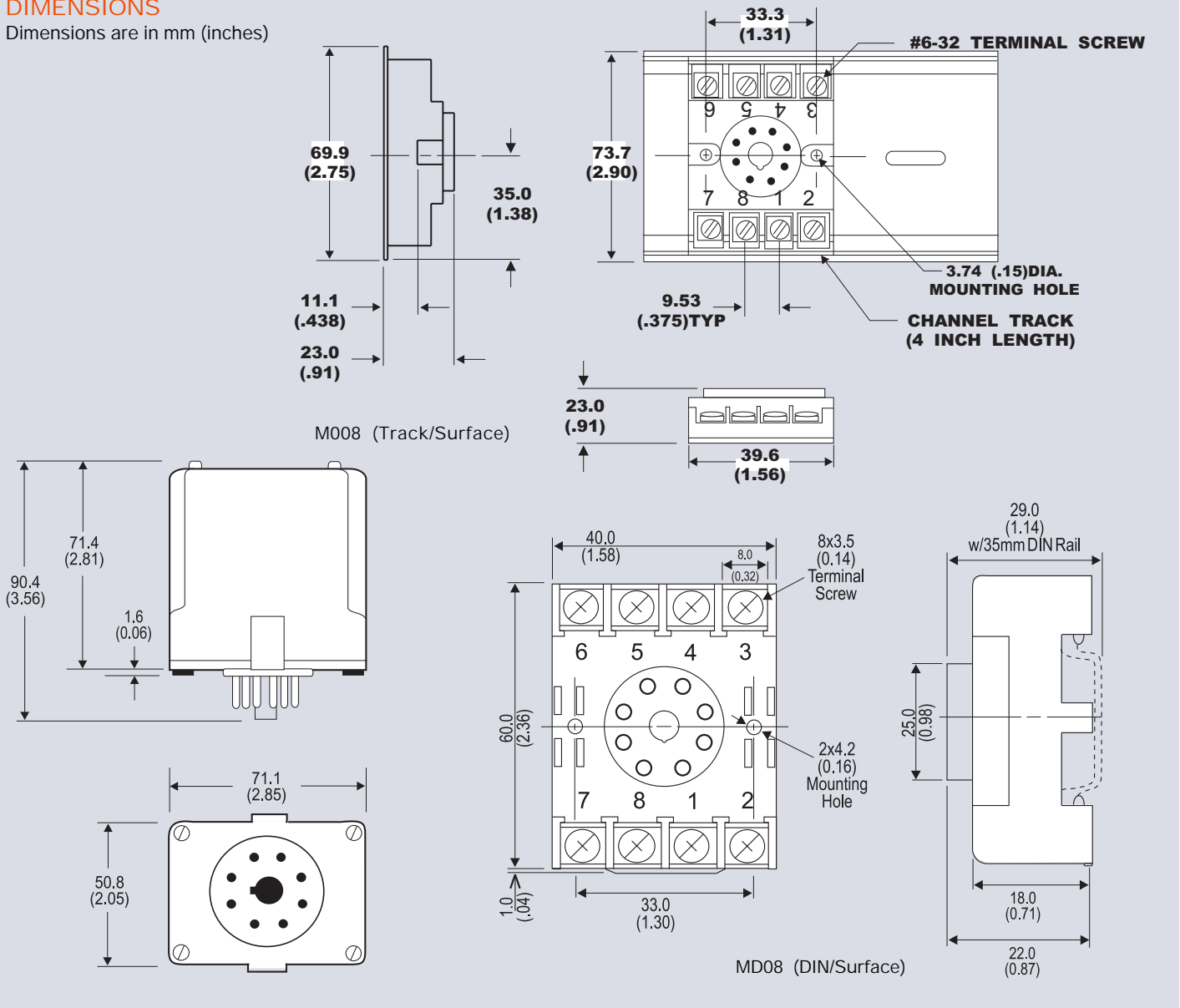

Figure 2: 120/240 VAC Selection

WARNING: Do not change with power connected!

DIMENSIONS

Dimensions are in mm (inches)



MODELS & ACCESSORIES

Mounting

All Action Paks feature plug-in installation. Model AP4382 uses an 8-pin base and either molded socket M008 or DIN socket MD08.

Ordering Information

Specify:

1. Model: AP4382
2. Option: U, see text
3. Line Power: 120/240 VAC or 9 to 30 VDC
4. Factory calibration (C620): Specify input range, output range and power.

(All power supplies are transformer-isolated from the internal circuitry.)

Pin Connections

- 1 Power (Hot)
- 2 Shield (Gnd)
- 3 Power (Neu)
- 4 Spare Termination
- 5 Input (+)
- 6 Input (-)
- 7 Output (+)
- 8 Output (-)

DC Power: PIN 1 = (+); PIN 3 = (-)

大连爱克新仪器有限公司

地址:辽宁省大连市中山区七七街23号海鹰大厦403室 邮编:116001

电话:0411-82650498 82597851 传真:0411-82650478

网址:爱克新产品 <http://www.actionio.com.cn>

e-mail:sales@actionio.com.cn support@actionio.com.cn



网址:欧陆产品 <http://www.eurotherm.com.cn>

e-mail:sales@eurotherm.com.cn support@eurotherm.com.cn