

**IR-AH SERIES
HAND-HELD TYPE
DIGITAL RADIATION THERMOMETER**



MODELS IR-AHS, IR-AHU, IR-AHT

Light weight and easy operation!!!

Models IR-AHS, IR-AHU and IR-AHT are the non-contact hand-held type digital radiation thermometers for portable measurement and logging of surface temperature.

The thermometers offer a wide measuring range of -50°C to 3000°C (-50 - 1000°C for IR-AHT, 600 - 3000°C for IR-AHS and 900 - 3000°C for IR-AHU), digital display of the measured value in a viewfinder and an LCD display, plus storage of measured data.

An RS-232C Serial port is provided to transmit the stored data to a personal computer. Optional Data Logging Software package IR-VXH2E allows management tagged with an index number for identification.



FEATURES

Data storage

Maximum 1000 data can be stored. Two storing modes are available. The manual storing mode is to store the measured data on demand and the interval storing mode is to store the measured data at the interval time programmed.

The data stored are readable on the display with index numbers for easy classification of data.

Easy-to-read internal and external digital display

A measured value is digitally displayed in the view finder and on the panel board.

RS-232C port

The communications interface port (RS-232C) is provided to transmit the measured data to a personal computer.

Signal modulation

Measurement modes of real value (real) maximum value (peak), average value (delay) and minimum value (valley) are selectable for measuring purposes.

Data logging software

The data logging software is separately prepared for the analysis and management of the measured data.

Analog output (option)

The analog output of 0 to 1VDC is offered at option. By using an AC power adapter (option), the continuous measurement is enabled.

Focusable Lens type

Easy to focus the object and sharp optical system

Other functions

Various functions including high/low alarms, °C / °F selection, auto-power-off, battery check and users' calibration (zero / span) are available.

**MODEL
IR - A H**

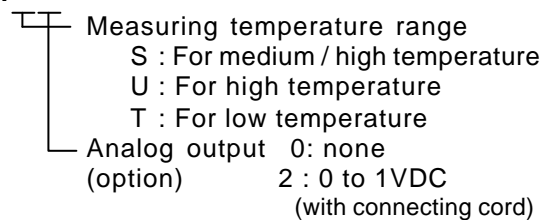

CE-MARKING

EN61326
Emission : Class B
Immunity : Table 1 - Minimum immunity test requirements
Directives: 89/336/EEC, 92/31 EEC amendment, 93/68/EEC amendment

Exceptions:
AC powered model (with AC power adapter) and analog output model are excluded from CE-marking. The thermometer connecting with the cord (IR-VHC3) for RS-232C is excluded from CE-marking.

■ GENERAL SPECIFICATIONS

Model	IR-AHS	IR-AHU	IR-AHT
Measuring System	Narrow band radiation thermometer		Wide band radiation thermometer
Detecting Element	Si		Thermopile
Measuring Wavelength	0.96 μ m	0.65 μ m	8 to 13 μ m
Measuring Range	600 to 3000°C	900 to 3000°C	-50 to 1000°C
Accuracy Ratings	Lower than 1500°C: $\pm 0.5\%$ of measured value ± 1 digit 1500°C to 2000°C: $\pm 1\%$ of measured value ± 1 digit Higher than 2000°C: $\pm 2\%$ of measured value ± 1 digit ($\tau = 1.0$, Reference operating condition: 23°C ± 5 °C, 35 to 75%RH)		Lower than 200°C: ± 2 °C ± 1 digit Higher than 200°C: $\pm 1\%$ of measured value ± 1 digit
Repeatability	1°C ± 1 digit		
Stability	1) Temperature drift: 0.015% of measured value / °C 2) Stability: ± 5 °C under EMC test environment		1) Temperature drift: Lower than 300°C: 0.15°C / °C 300 - 700°C: 0.05% of measured value / °C Higher than 700°C: 0.025% of measured value / °C 2) Stability: ± 15 °C under EMC test environment
Resolution	1°C		1°C (higher than 50°C)
Response Time	0.5 second		1 second
Emissivity Compensation	=1.00 to 0.10 (0.01 increment)		
Signal Modulation	Modulation: Real, Peak, Delay, and Valley Modulation ratio: 0 to 99 seconds, 1-sec increment Peak hold, Valley hold, Hold with the measuring switch turned off		
Display System	LCD digital 4 digits, Displayed in the viewfinder and on the panel board		
Data Storage Function	Maximum 1000 data		
Users' Calibration Function	Calibration at zero and span		
Output Signal	Digital transmission (RS-232C), Analog output (0 to 1VDC, option) with a cord		
Optical System	Focusable lens type		Cassegrain focusable mirror type
Distance Factor	100 (Measuring distance L / Measuring diameter D)	250 (Measuring distance L / Measuring diameter D)	40 (Measuring distance L / Measuring diameter D)
Measuring Distance	L = 500mm to		L = 700mm to
Measuring Diameter	D = L / 100(ϕ , mm)	D = L / 250(ϕ , mm)	D = L / 40(ϕ , mm)
Collimation	Direct viewing finder		
Lens Diameter	ϕ 30mm		ϕ 40mm
Other Functions	Auto-power-off, Continuous measurement, °C / °F selection, Battery check, High / low alarms		
Working Temperature	0 to 50°C		
Power Supply	AA (UM-3) battery, 4 pieces (about 20 hours for continuous measurement)		
Casing Material and Color	ABS resin, Gray		
Outside Dimensions and Weight	W135 x H60 x D175mm, About 700g (thermometer only)		
Attachment	4 pieces of AA (UM-3 battery), Adapter for tripod, Housing case		

■ DATA LOGGING SOFTWARE / IR-VXH2E

Three kinds of data management mode, real-time trend mode, multi-point monitoring mode by utilizing memory, and 1-point historical trend mode, are available. Graph display, report creation, printing, and data storage can be easily executed. The export of the measured data to spreadsheet applications is also possible.

General specifications		Model	• IR-VXH2E			
		Environment	• OS Windows 98 or Windows 95 (Minimum 10MB is required to install.)			
General specifications		Media	• CD-R (2 m of RS-232C cable with D-SUB 9 pins female connector for DOS/V PC is attached.)			
		Readout	• Readout of transmitted data by RS-232C from IR-AHS, IR-AHU or IR-AHT			
		Functions	• Display on a personal computer • Data storage and playback • Printer output			
		Graphic display	• 640 x 480 dots (initial) • 1024 x 768 dots (resized by a personal computer)			
		Measurement mode	• Multi-point monitoring mode (30 points) • 1-point trend mode(1000 data) • Real-time trend			
				Real-time trend	Multi-point Monitoring (30 points)	1-point trend
		Readout of data	Readout of data stored	• Real-time trend graph (in real-time trend logging mode) • Alarm summary		
Data logging and graphic display	<ul style="list-style-type: none"> • Measuring cycle: 0.5 to 10 seconds • Chart speed: 10-second, 1-minute, 5-minute, 10-minute, 1-hour, 2-hour/screen (6-step selection) • Scroll function: Chart time axis can be scrolled after measurement stop or playback of data stored • Temperature range: Auto-range or fixed range is selectable.) • High/low alarms • Alarm summary (at stop of data logging) 					
Storage/output	Storage type	• File for various trend graphs	• Storage of 30 points data base	<ul style="list-style-type: none"> • Readout of continuous data up to 1000 data • Display by graph • Display of all data • Display of specified data (100 points/10 points selectable) • Maximum, minimum and average 		
	Export to Excel 97 (*)	• All data of date, time and temperature on real-time trend • Alarm summary	• Monitoring data base table up to 30 points			
	Data stored	• Maximum 1000 data (Maximum memory capacity 600KB) • Alarm summary 100 data (Renewed to up-dated data)	• Data base up to 30 points			
	Printer output	• Real-time trend graph • Alarm summary report	• Table form report • Graph form report			

(*) On condition that Excel 97 has been installed on a personal computer.

Note: Windows 98, Windows 95 and Microsoft Excel 97 are registered trademarks of Microsoft Corporation in the United States.

■ **OPTIONS/ACCESSORIES**

Option	Model	Name	Specification
	IR-AH 2 *	Analog output	0 to 1VDC, with 2m cord
Accessory	IR-VHR *	AC power adapter	
	IR-ZBMT	Tripod	
	IR-VMS	Universal head	
	IR-VHC3 *	RS-232C cord	D-SUB 9 pins ↔ 3P jack, 2m

* marked are not available for CE-marking (EMC directive)

■ **CLOSE-UP LENS**

For measurement of measuring distance shorter than 0.5m

Model	Measuring distance	Min. measuring diameter (IR-AHS)	Min. measuring diameter (IR-AHU)
IR-VHD13	100 to 130 (mm)	ø1.0 to ø1.3mm	
IR-VHD18	130 to 180 (mm)	ø1.3 to ø1.8mm	
IR-VHD29	180 to 290 (mm)	ø1.8 to ø2.9mm	ø0.7 to ø1.2mm
IR-VHD54	250 to 540 (mm)	ø2.5 to ø5.4mm	ø1.0 to ø2.2mm

EXTERNAL DIMENTIONS

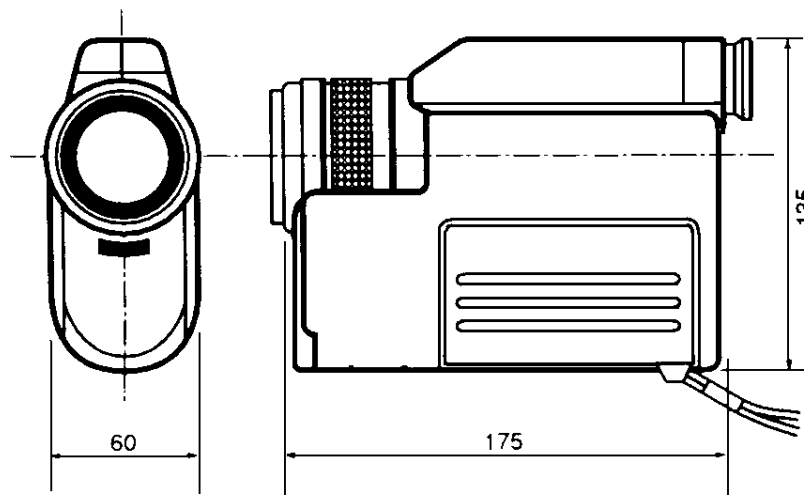

Unit: mm