

# TRANSPAK™ T761 MODEL



## Benefits

- Eliminates Ground Loops
- Easy Field Configurable Switch Selectable Input Ranges
- Wide Ranging Zero and Span Adjustability (80%)
- Protects Equipment with 600V Input-to-Output Isolation
- Three Year Warranty



## AC Input Isolating, Field Configurable Two-Wire Transmitter

Provides an Isolated Current Loop in Proportion to an AC Input

### DESCRIPTION

The T761 offers the user a choice of 12 widely adjustable input ranges and 2 output ranges, which are field selectable via top-accessed DIP switches (see Table 1). The T761 provides 600 VDC of isolation with outputs of either 4-20mA or 10-50mA. Current outputs are in proportion to selected AC voltage or current input.

Model T761 measures the average value of the AC input signal and is calibrated for sine wave signals over a frequency range of 20Hz to 3KHz. For other wave forms, the calibration may be different, but the T761 will remain linear for the same wave form. For example, if the unit is calibrated using a square wave, the calibration will be valid for all square wave inputs in that range. The maximum DC component of the input signal is 50% of the range (e.g., 75VDC is half of a 0-150VAC range).

A major advantage of the T700 Series is their truly wide ranging capability. The T761 enables 80% zero and span adjustability within most user-selected input ranges. For example, Range 3 of Table 1 specifies 0 to 25V with a minimum span of 5V (25V-5V = 20V, or 80%). This 80% adjustability factor allows the user to field-calibrate the unit for the maximum (0 to 25V) down to any minimum (5V) span (e.g. 10V to 15V)--as long as that adjusted span remains within the selected 0 to 25V range.

### APPLICATION

Model T761 is useful in any application requiring an isolated two wire loop current from an AC signal source. Typical applications include AC motor status and energy management. The output of the T761 can be used to drive a digital meter for direct display or interface with a computer for monitoring and control.



*Protecting the  
Integrity of  
Industrial  
Process Signals*



## OPTION

- U Urethane coating of internal circuitry for protection from corrosive atmospheres
- C620 Factory calibration to customer's specifications

## CALIBRATION

1. Open the access lid on the top of the unit (see Top View Diagrams).
2. Select the output range using switch S1. The CLOSED position selects a 10-50mA output. The OPEN position selects a 4-20mA output.
3. Select input range from Table 1 and configure switches S2 through S6.
4. Connect the input to a calibrated AC voltage or current source. Connect the output loop to a voltage supply and monitor the output current (refer to terminal wiring).
5. Set the calibrator to the desired minimum.
6. Adjust the coarse zero rotary switch to obtain an output of either 4mA or 10mA. Adjust the fine zero for exact calibration. Note

**Table 1: T761 Input Ranges**

| Input Range | Input Limits | Minimum Span | Range Selection Switch Position |        |        |        |        |
|-------------|--------------|--------------|---------------------------------|--------|--------|--------|--------|
|             |              |              | S2                              | S3     | S4     | S5     | S6     |
| 1           | 0-250VAC     | 100VAC       | OPEN                            | CLOSED | OPEN   | OPEN   | CLOSED |
| 2           | 0-100VAC     | 20VAC        | OPEN                            | CLOSED | OPEN   | OPEN   | OPEN   |
| 3           | 0-25VAC      | 5VAC         | OPEN                            | CLOSED | OPEN   | CLOSED | CLOSED |
| 4           | 0-5VAC       | 1VAC         | OPEN                            | CLOSED | OPEN   | CLOSED | OPEN   |
| 5           | 0-1VAC       | 0,2VAC       | OPEN                            | OPEN   | CLOSED | OPEN   | CLOSED |
| 6           | 0-200mVAC    | 40mVAC       | OPEN                            | OPEN   | CLOSED | OPEN   | OPEN   |
| 7           | 0-50mVAC     | 10mVAC       | OPEN                            | OPEN   | CLOSED | CLOSED | CLOSED |
| 8           | 0-10mVAC     | 2mVAC        | OPEN                            | OPEN   | CLOSED | CLOSED | OPEN   |
| 9           | 0-2A AC      | 0,4A AC      | CLOSED                          | OPEN   | CLOSED | OPEN   | CLOSED |
| 10          | 0-4mA AC     | 80mA AC      | CLOSED                          | OPEN   | CLOSED | OPEN   | OPEN   |
| 11          | 0-100mA AC   | 20mA AC      | CLOSED                          | OPEN   | CLOSED | CLOSED | CLOSED |
| 12          | 0-20mA AC    | 4mA AC       | CLOSED                          | OPEN   | CLOSED | CLOSED | OPEN   |

that it may become necessary to switch coarse zero up or down one position.

7. Set the calibrator to the desired maximum and adjust the fine span to obtain an output of either 20mA or 50mA. Repeat steps 5-7, if necessary for best accuracy.

## TERMINAL CONNECTIONS

- 1 Loop Output (-)
- 2 Loop Output (+)
- 3 No Connection
- 4 Input
- 5 Input
- 6 Shield (Gnd)

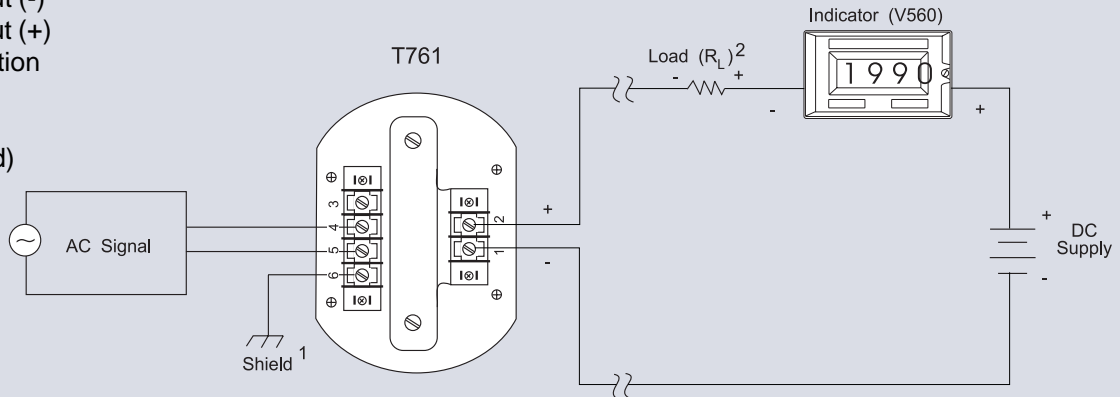

- 1 Note: For best RF & common mode rejection ground the case (pin 6).
- 2 Note:  $R_L$  represents any other device loads in the current loop.

## TOP VIEW DIAGRAM

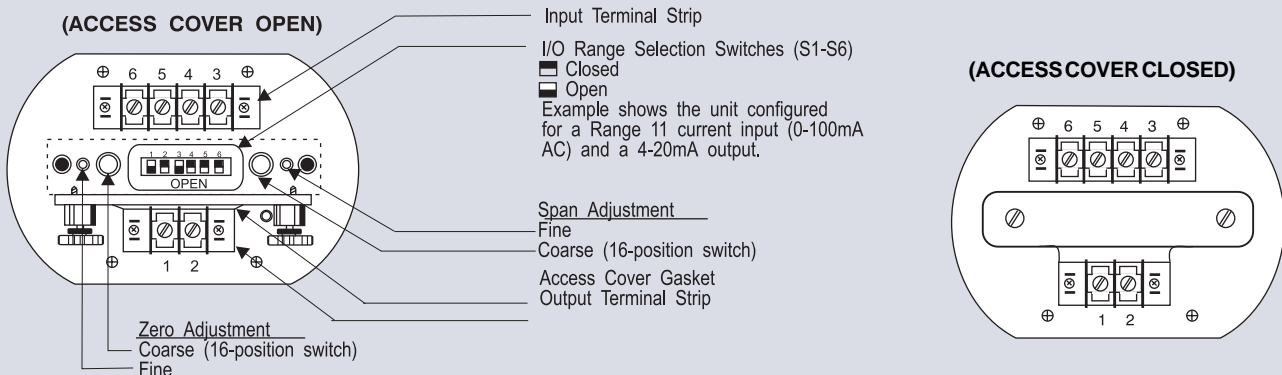

## SPECIFICATIONS

|  |  |
|--|--|
| <b>Input Span Range (Max/Min)</b>              | See table 1  |
| <b>Leadwire Resistance Effect</b>              | < 0.25 $\mu\text{V}/\Omega$                                  |
| <b>Input Impedance</b>                         | Ranges 1-8: > 1M $\Omega$<br>Ranges 9-12: 0.5 $\Omega$ shunt |
| <b>Output Span</b>                             | 4-20mA/10-50mA, switch selectable                            |
| <b>Minimum Output Current</b>                  | 3.3mA, typical   |
| <b>Maximum Output Current</b>                  | 4-20mA: 24mA, typical<br>10-50mA: 58mA, typical              |
| <b>Supply-Voltage Range</b>                    | 4-20mA: 12 to 80VDC<br>10-50mA: 12 to 60VDC                  |
| <b>Maximum Change in supply Voltage Effect</b> | 0.05% of span  |
| <b>Maximum Change in Load Effect</b>           | 0.05% of span  |
| <b>Loop Voltage Drop</b>                       | 12VDC @ 20mA   |

|   |   |
|---|---|
| <b>Stability</b>  | Zero: $\pm 0.02\%$ of span/ $^{\circ}\text{C}$ , typical, or 10 $\mu\text{V}/^{\circ}\text{C}$ , whichever is greater<br>Span: $\pm 0.02\%$ of span/ $^{\circ}\text{C}$ , typical |
| <b>Overall Accuracy (Includes Linearity, Hysteresis, Stability)</b> | $\pm 0.5\%$ of any adjusted span (50-400Hz sine wave input), max.   |
| <b>Frequency Response (<math>\pm 0.5\text{dB}</math>)</b>           | 20Hz to 3KHz; average reading calibrated to sine wave input   |
| <b>Maximum DC Input Component Zero and Span Adjustability</b>       | 50% of range<br>80% of any selected range   |
| <b>Repeatability</b>  | $\pm 0.05\%$ of span, typical   |
| <b>Response Time</b>  | 500ms, typical  |
| <b>Output Ripple</b>  | 0.5% of span, rms, typical  |
| <b>RFI Effect (5W, 470MHz at 3 Ft.)</b>                             | < 1% of span error  |
| <b>Isolation</b>  | 600V DC maximum, input to output  |
| <b>Temperature Range</b>  | Operating: -40 to 80 $^{\circ}\text{C}$ (-40 to 176 $^{\circ}\text{F}$ )  |
| <b>Weight</b>   | 0.64lbs   |

## MOUNTING HARDWARE

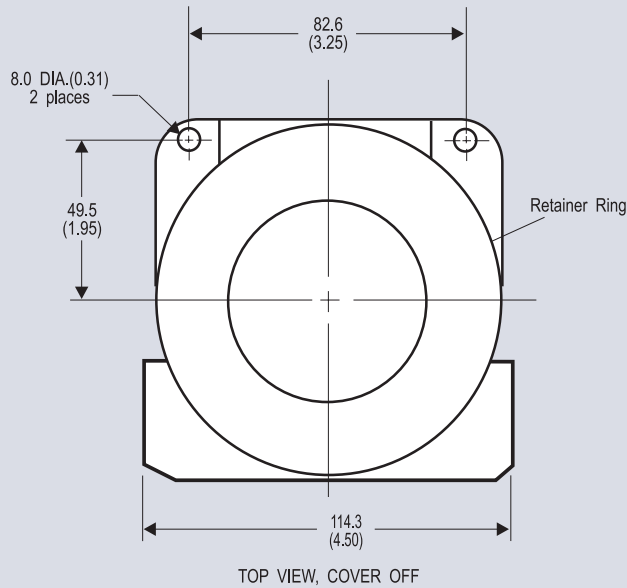

T805 Field Mountable Housing (EP, NEMA 4 rated) 3/4" Hub  
(Includes T903 Retainer Ring and NEMA 4 Gasket)

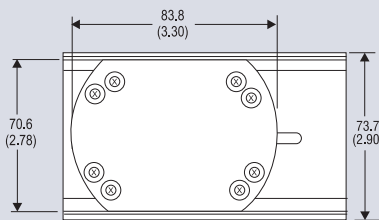
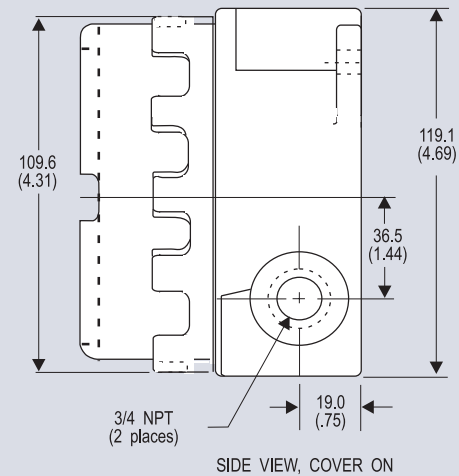

T902 MOUNTING PLATE  
(For snap-track mounting;  
includes snap track)  
Aluminum Alloy #6061 (0.06in, thick)

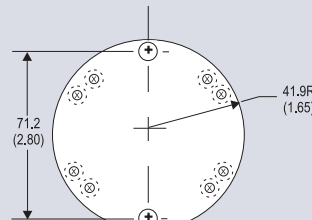

T910 MOUNTING PLATE  
(For bulkhead mounting)  
Aluminum Alloy #6061 (0.06in, thick)

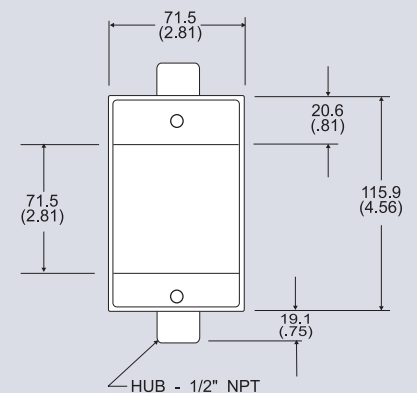
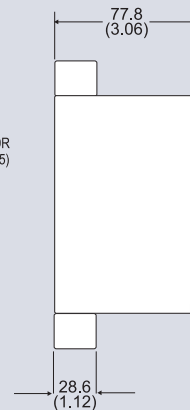

T804 Conduit Device Housing

## DIMENSIONS/ASSEMBLY DIAGRAM

Dimensions are in Millimeters (Inches)

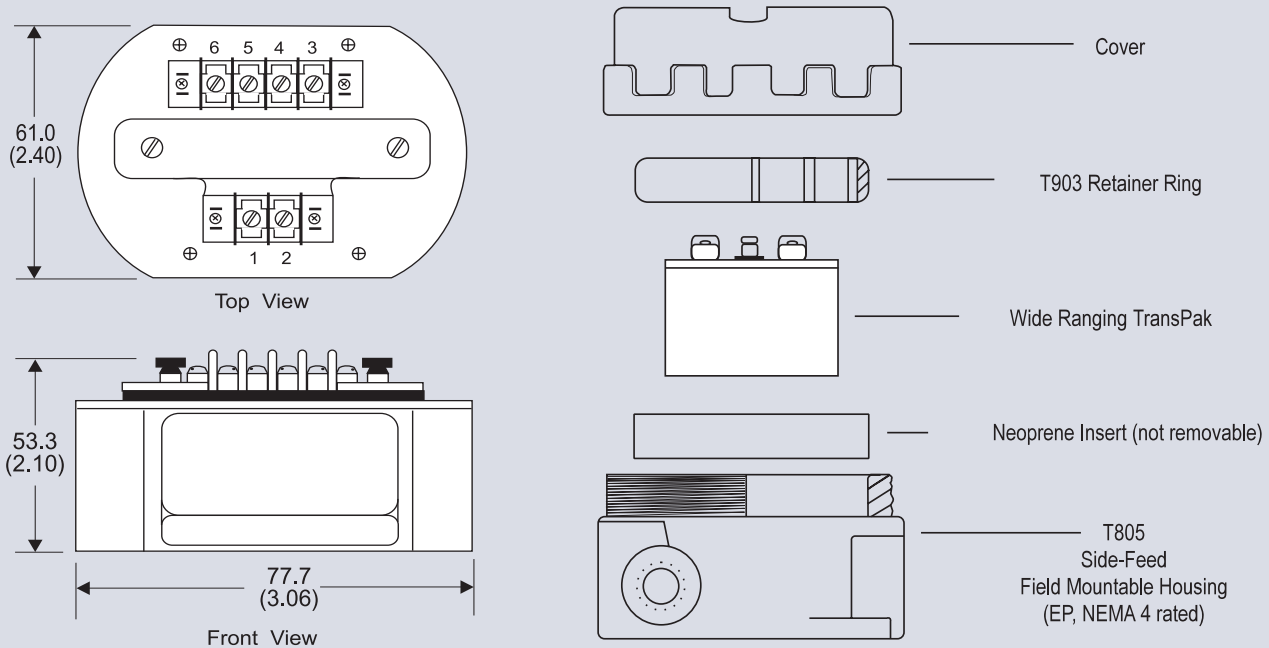

## FIELD-MOUNTING

The T761 is designed for installation in industrial field environments. A sealed, die-cast aluminum housing protects against corrosion, moisture, dust and electrical noise such as radio-frequency (RFI) and electromagnetic (EMI) interference.

For protection against extreme moisture, hose-directed water (NEMA 4) or hazardous environments, use Action's T805 explosion-proof housing. The T805 provides ready-to-install plumbing ports for easy hook-up and operation in harsh process environments. Model T805 is FM and CSA certified for use in Class I, Groups B, C & D and Class II, Groups E, F & G hazardous locations.

## MODELS & ACCESSORIES

### Accessories

| Model  | Description   |
|--------|---|
| M004   | Snap-in Channel Track, 4 feet.  |
| T902   | Mounting plate for M004, includes 4" track.   |
| T910   | Bulkhead (flat surface) Mounting plate.   |
| T804   | Conduit device housing.   |
| T805   | Side feed field-mountable housing (EP & NEMA 4 rated), uncoated (specify Option P for white polyester powder coat).                                 |
| C006   | 0.1W, 5W, 1% shunt resistor   |
| AP9046 | Action Pak 24/40VDC 65mA Power Supply.  |
| T609   | 24V, 600mA Loop Power Supply.   |
| V565   | 3-1/2 digit remote loop-powered indicator, wide-ranging display, NEMA 4X enclosure, CSA & FM approval standard, specify Option C to house TransPak. |

### Ordering Information

#### Specify:

1. Model: **T761-0000**
2. Options: U (Urethane coating)
3. Optional Custom Factory Calibration: Specify **C620** with desired input and output range.

**大连爱克新仪器有限公司**

地址: 辽宁省大连市中山区七七街23号403室

电话: 0411-82650498 82597851 13909856458

传真: 0411-82650478 邮编: 116001

E-mail: sales@actionio.com.cn xctlcy@mail.dlptt.ln.cn  
support@actionio.com.cn

[www.actionio.com.cn](http://www.actionio.com.cn)



**DALIAN ACTION INSTRUMENTS**