

TRANSPAK™ T773 MODEL



Benefits

- Eliminates Ground Loops
- Digitally-Synthesized, Field Configurable, Switch Selectable Ranges (105Hz to 18kHz)
- Wide Ranging Zero (30%) and Span (80%) Adjustability
- Direct Magnetic Pickup Input
- Velocity/Flow Applications
- Protects Equipment with 1000VRMS Isolation
- Three Year Warranty



Frequency Input Isolating, Field Configurable Two-Wire Transmitter

Provides an Isolated Current Loop in Proportion to a Frequency Input

DESCRIPTION

The T773 offers the user a choice of 5 input ranges and 2 output ranges, which are field selectable via top-accessed DIP switches (see Table 1). The T773 isolating two-wire transmitter can accept square, triangle or pulse waveforms up to 18KHz with amplitudes from 10mVrms to 35V peak-to-peak. The T773 provides 1000Vrms of transformer-coupled isolation with outputs of either 4-20mA or 10-50mA. Current outputs are in proportion to a selected frequency input. A major advantage of the T773 is its truly wide-ranging capability. The T773 enables 30% zero “turn-up” and 80% span “turn-down” adjustments within any user-selected input range. For example, Range 3 of Table 1 specifies 0 to 2100Hz with a minimum span of 420Hz (2100Hz - 420Hz = 1680Hz, or 80%). This 80% adjustability factor allows the user to field calibrate the unit for the maximum range of 0 to 2100Hz down to the minimum range of 0 to 420Hz. The maximum obtainable offset is 30% of the calibrated span: a calibrated range of 0 of 1000 Hz can be offset by 300Hz (e.g., 300Hz to 1000Hz).

APPLICATION

Model T773 is useful in any application requiring an isolated two-wire loop current from a pulse output transducer, such as a magnetic pickup or a turbine flowmeter. The output of the T773 can be used to drive a digital meter for direct display of flow or velocity, or to interface with a computer or PLC for monitoring and control applications.

The model T773 is CSA approved for intrinsically safe operation in Class I, Division 1, Groups A, B, C and D hazardous locations when installed per manufacturing drawing number.



*Protecting the
Integrity of
Industrial
Process Signals*



Table 1: T773 Input Ranges

Input Range	Input Limits	Minimum Span	To select range, position switch:				
			S1	S2	S3	S4	S5
1	0-18KHz	3600Hz	OPEN	OPEN	OPEN	CLOSED	OPEN
2	0-9000Hz	1800Hz	OPEN	OPEN	CLOSED	OPEN	OPEN
3	0-2100Hz	420Hz	OPEN	CLOSED	OPEN	OPEN	CLOSED
4	0-525Hz	105Hz	CLOSED	OPEN	OPEN	OPEN	CLOSED

OPTION

U Urethane Coating of internal circuitry for protection from corrosive atmospheres.

CALIBRATION

Note: Factory settings are: Input Range 1; 4-20mA output.

1. Open the access lid on the top of the unit (see Top View Diagrams).
2. Select the output range using switch S6. The CLOSED position selects a 10-50mA output. The OPEN position selects a 4-20mA output.
3. Select input range from Table 1 and configure switches S1 through S5.
4. Determine percent of span by the ratio of

desired maximum input to the input limit in Table 1 (e.g., 1000Hz/2100Hz = 48%).

5. Set step Span rotary switch to the desired percent of span (e.g., 48% = position 4).

Percent of Span	Position
100%	A
90%	9
80%	8
70%	7
60%	6
50%	5
40%	4
30%	3
20%	2

6. Determine Zero turn-up % by the ratio of desired minimum input to the desired maximum input (e.g., 0/1000Hz = 0%).

7. Set step Zero turn-up switch to offset %. (e.g., 0% = position 0).

Zero Turn-Up %	Position
0%	0
£10%	1
£20%	2
£30%	3

8. Connect the input to a calibrated frequency source. Connect the output loop to a voltage supply and monitor output current (refer to terminal wiring).

9. Set the calibrator to the desired minimum and adjust the fine zero to obtain an output of either 4mA or 10mA.

10. Set the calibrator to the desired maximum and adjust the fine span to obtain an output of either 20mA or 50mA. Repeat steps 9 and 10, if necessary, for maximum accuracy.

Note: If loop current swings on input ranges 1-2, close S-5 for extra filtering.

TERMINAL WIRING

Terminal Connections
T773

- 1 Loop Output (-)
- 2 Loop Output (+)
- 3 No Connection
- 4 Input Frequency
- 5 Input Frequency
- 6 Shield (Case)

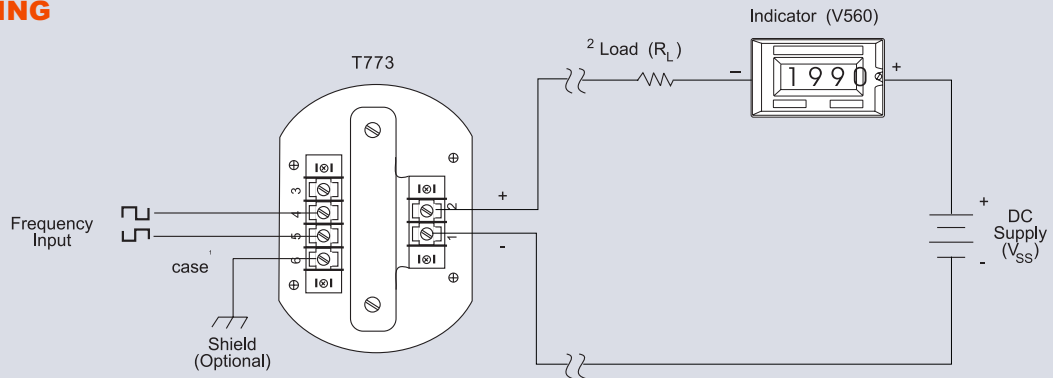

- Notes:
2. Case (pin 6) must be grounded for effective RF and Common Mode rejection, whether or not the wiring has an earth reference.
 3. R_L represents any other device loads in the current loop.

TOP VIEW DIAGRAMS

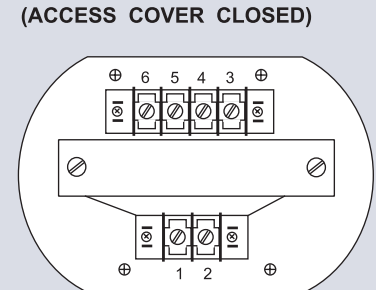
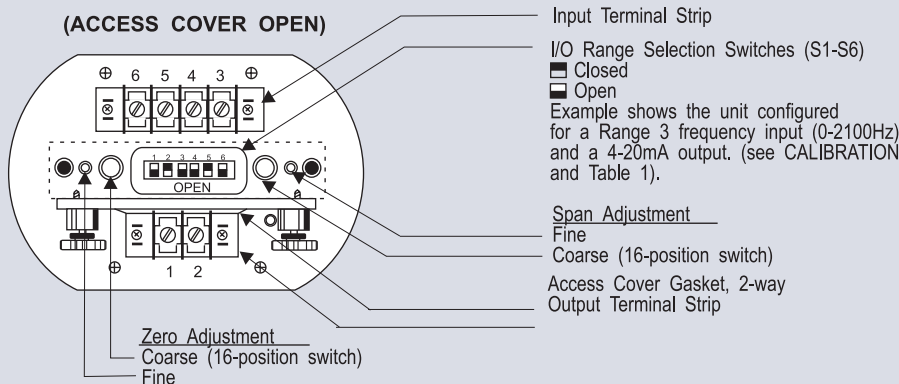

SPECIFICATIONS

Input	Span Range (Max/Min) See Table 1 Type: Capacitive coupled Minimum Amplitude: 105-2150Hz: 10mVrms >2150Hz: 15mVrms Maximum Amplitude: 235V p-p	Repeatability	±0.05% of span
Impedance	100-1KHz: >6KΩ >1KHz: >40KΩ	Response Time (63% response)	<9KHz: 500mSec. >9KHz: 40mSec.
Output Span	4-20mA/10-50mA, switch selectable	Output Ripple, P-P (% at max. input range frequency; 0% turn-down)	Range 1: 0.5% (18KHz) Range 2: 0.5% (9KHz) Range 3: 0.7% (2100Hz) Range 4: 1.2% (525Hz) Range 5: 4% (260Hz) <i>Note: Range 5 at frequencies below 52Hz will exceed 4% output ripple.</i>
Minimum Output Current	3.3mA, typical	Common Mode Rejection	60Hz: 97dB, DC: 120dB
Maximum Output Current	4-20mA: 24mA, typical 10-50mA: 58mA, typical	Common Mode Range	60Hz: 75Vrms, max. DC: 1KV, max.
Supply Voltage Range	4-20mA: 13 to 75VDC 10-50mA: 13 to 50VDC	RFI Effect (1.5W, 470MHz at 1.5 ft.)	< 1% of span error
Line Regulation	0.07% of span (13-75V)	Isolation	1000Vrms maximum input to output, input to case, output to case
Load Regulation	0.05% of span (0-3KΩ)	Operating Temperature Range	4-20mA: -40 to 80°C (-40 to 176°F) 10-50mA: -40 to 60°C (-40 to 140°F)
Voltage Drop	13VDC @ 20mA	Weight	0.58lbs
Stability	Zero: ±0.015% of span/°C, typical, ±0.028%/°C, max. Span: ±0.022% of span/°C, typical, ±0.043%/°C, max.	Agency Approval	CSA approved intrinsically safe for hazardous locations (File No. LR42272-70). FM approval pending.
Overall Accuracy (Includes best straight line Linearity, Hysteresis, Stability)	±0.2% of adjusted span, max.		
Zero Adjustability	30% "turn-up" of span		
Span Adjustability	80% "turn-down" of full-scale limit (Table 1)		

DIMENSIONS/ASSEMBLY DIAGRAM

Dimensions are in Millimeters (Inches)

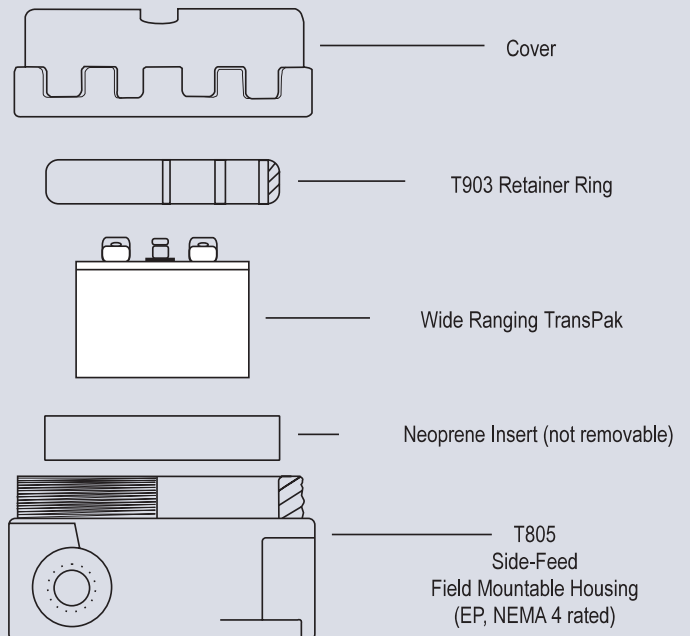
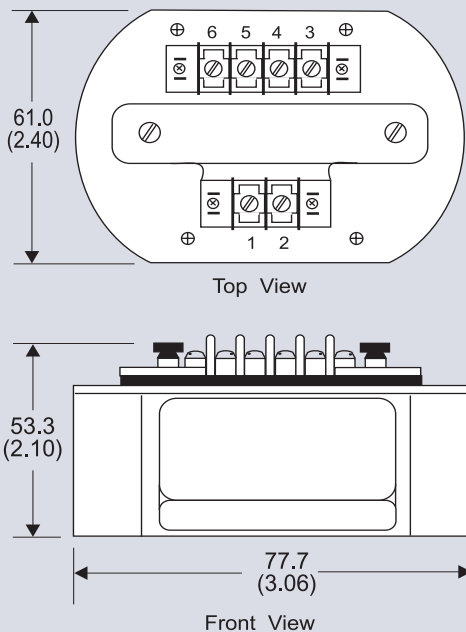

MOUNTING HARDWARE

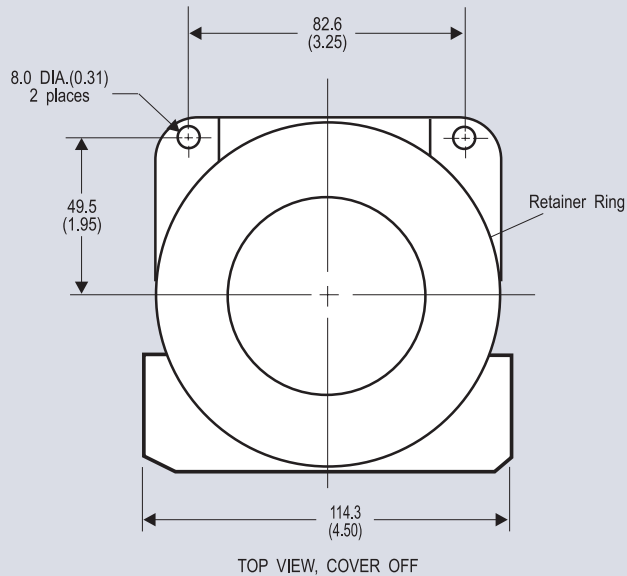

T805 Field Mountable Housing (EP, NEMA 4 rated) 3/4" Hub
(Includes T903 Retainer Ring and NEMA 4 Gasket)

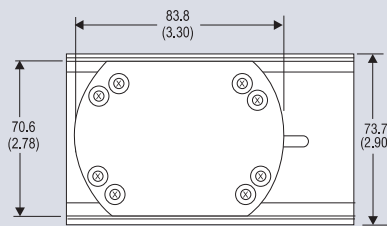
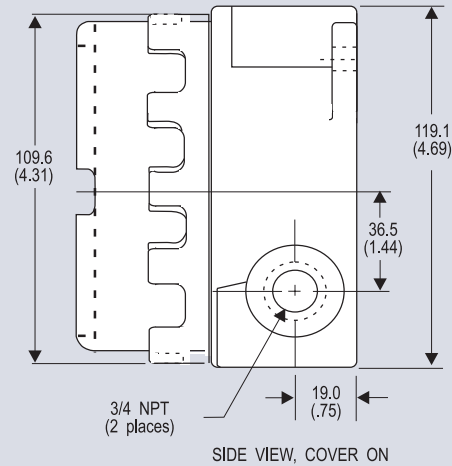

T902 MOUNTING PLATE
(For snap-track mounting;
includes snap track)
Aluminum Alloy #6061 (0.06in, thick)

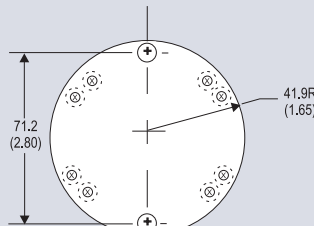

T910 MOUNTING PLATE
(For bulkhead mounting)
Aluminum Alloy #6061 (0.06in, thick)

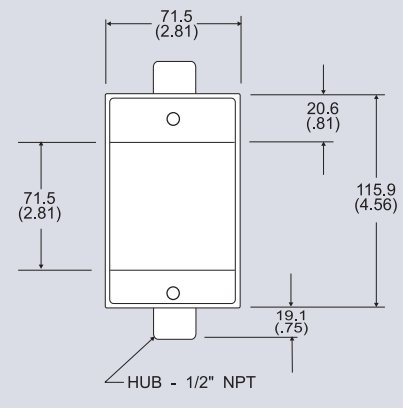
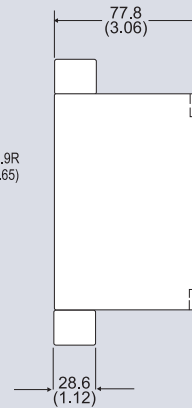

T804 Conduit Device Housing

FIELD-MOUNTING

The T773 is designed for installation in industrial field environments. A sealed, die-cast aluminum housing protects against corrosion, moisture, dust and electrical noise such as radio-frequency (RFI) and electromagnetic (EMI) interference.

For protection against extreme moisture, hose-directed water (NEMA 4) or hazardous environments, use Action's T805 Field-mountable housing. The T805 provides ready-to-install plumbing ports for easy hook-up and operation in harsh process environments. Model T805 is FM and CSA certified for use in Class I, Groups B, C, & D and Class II, Groups E, F & G hazardous locations.

MODELS & ACCESSORIES

Accessories

Model	Description
M004	Snap-in Channel Track, 4 feet.
T902	Mounting plate for M004, includes 4" track.
T910	Bulkhead (flat surface) Mounting plate.
T804	Conduit device housing.
T805	Side feed field-mountable housing (EP & NEMA 4 rated), uncoated (specify Option P for white polyester powder coat).
9046	Action Pak 24/40VDC, 65mA Power Supply.
T609	24V, 600mA Loop Power Supply.
V565	3-1/2 digit remote loop-powered indicator, wide-ranging display, NEMA 4X enclosure, CSA & FM approval standard, specify Option C to house TransPak.

Ordering Information

Specify:

1. Model T773-0000
2. Option: U
3. Optional Custom Factory Calibration: Specify C620 with desired input and output range.

大连爱克新仪器有限公司

地址:辽宁省大连市中山区七七街23号403室

电话: 0411-82650498 82597851 13909856458

传真: 0411-82650478 邮编: 116001

E-mail: sales@actionio.com.cn xctlcy@mail.dlptt.ln.cn
support@actionio.com.cn

www.actionio.com.cn



DALIAN ACTION INSTRUMENTS